

Replaceable Solid Core Type Filter Drier Shells



INTRODUCTION

'SANLAN' replaceable solid core type filter drier shells are specially designed for liquid line application for working media of fluorinated refrigerants. Core blocks must be ordered separately from the filter drier shell. Standard 48 cu. in. size blocks of international brands like Sporlan, Danfoss, Alco or Castel can be used. They are supplied in individual packages, which are hermetically sealed in suitable wrappings and in specially bag for safe storage over long periods of time.

TECHNICAL INFORMATION

'SANLAN' Filter Drier Shells are manufactured in steel. The side connections are made of copper in order to facilitate soldering to piping.

The hollow cylinder shape offers a large surface area to the inflowing fluid, which crosses the block radially. As a result, dehydration is highly efficient with a minimum loss of charge.

In the case of filters with more than one block, the passage of the fluid takes place in parallel; as a result the pressure drop does not increase proportionately to the number of blocks. A large ring between the block and the inner surface of the filter permits the accumulation of solid particles, and prevents clogging.

Before leaving the filter, the refrigerant fluid must pass through the mesh sieve on which blocks are mounted. The danger of small particles of dehydrating material being introduced into the system is thus avoided.

SPECIFICATIONS

Safe Working Pressure SWP: - 32 bar/450psig.

Kindly refer the following table to select the proper filter drier shell as per the requirement.

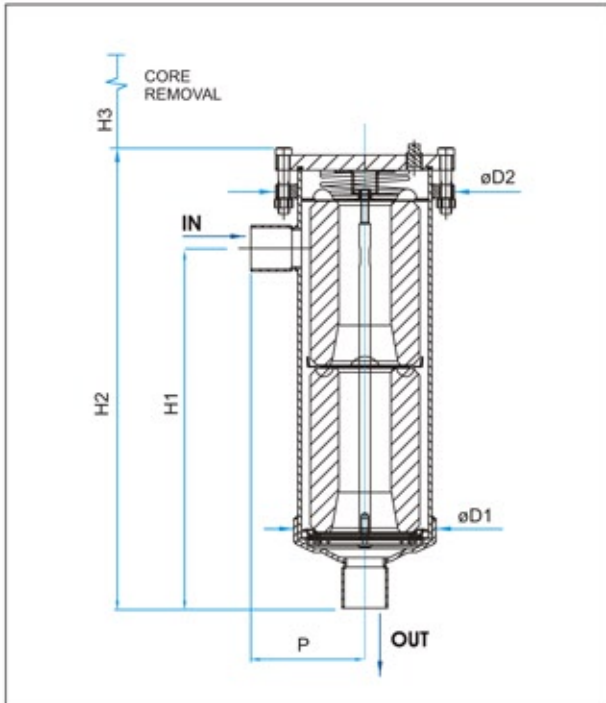

Type	Code No.	Blocks No.	Desiccant Volume	Connections* Solder	Dia.D1	Dia.D2	H1	H2	H3	P	Weight
			Cu.in.	ODS in.	mm	mm	mm	mm	mm	mm	kg.
Single Core	48-1-7-S	1	48	7/8"	121	152	179	257	185	102	4.1
	48-1-9-S			<u>1 1/8"</u>							
Two Core	48-2-9-S	2	96	1 1/8"			319	400	325	101	5.5
	48-2-11-S			<u>1 3/8"</u>							
Three Core	48-3-11-S	3	144	1 3/8"			458	543	100	6.7	
	48-3-13-S			<u>1 5/8"</u>							
Four Core	48-4-13-S	4	192	1 5/8"			594	685	97	8	
	48-4-17-S			<u>2 1/8"</u>							

*Note:

1) Underlined Connections are Standard Connections

2) Solder connections other than specified in the table OR Weldable type steel connections can be provided on special request.



475 - B, Shukrawar Peth, Subhash Nagar, Lane No. 1, Pune - 411 002 (Maharashtra) India.
 Ph. : 91-020-24421400, 24493671, 24475851 Email : contact@sanlancontrols.com
 Web : www.sanlancontrols.com